



FIAT DUCATO, PEUGEOT BOXER, CITROËN JUMPER AL-KO CHASSIS TECHNOLOGY



AL-KO VEHICLE TECHNOLOGY

QUALITY FOR LIFE

FROM THE VILLAGE FORGE TO A GLOBAL CORPORATION

Our roots were planted in a small village smithy. The fact that a global corporation has emerged from these humble roots is also because we are constantly aware of what our identity represents and what values the company has always embodied: Quality, innovation in product and process as well as reliability and sustainability in our internal and external customer relations. That is the basis of our pursuit for sustainable growth and market leadership in our business divisions.

Since 2016 we have made our contribution to the DexKo Group, the world's leading manufacturers of axles and chassis components in the lightweight segment. We are proud to continue in successfully shaping this development together with the DexKo and to convey our brand promise of quality, safety and comfort for our products and services to the world.



LIFE FOR QUALITY

We love quality. We live quality. And we have the right answer for virtually all transport requirements in our sector. AL-KO Vehicle Technology is safety and quality in one: from the product to delivery. We want our customers to be satisfied and successful. **Quality for life!**



FOR WHEN THE BEST IS EXPECTED

Founded in 1931, AL-KO Vehicle Technology is now a global technology company with around 30 sites in Europe, South America, Asia and Australia. Offering high-quality chassis components for trailers, leisure vehicles and light commercial vehicles, AL-KO stands for optimum ergonomics and functionality, highest comfort as well as innovations for greater driving safety.

Every year AL-KO manufactures a five-digit number of innovative automotive chassis in five works worldwide. The largest production facility is the works in Ettenbeuren in the south of Germany.



RESEARCH AND DEVELOPMENT

Research and development are firmly involved in the product creation process from the initial idea right through to production. The result: Innovative solutions that satisfy the most demanding requirements. In close coordination and collaboration with the state-of-the-art Testing Department, our engineers at the new Technology Centre push individual components, assemblies, and even finished products to the limit every day.

We are proud of our customized, state-of-the-art testing facilities that enable the most stringent service life and wear tests in real application conditions. In our market environment, they offer unique opportunities for the testing of individual components and entire vehicles. Only what is assessed as flawless finally receives our „Quality for Life“ award!





AL-KO CHASSIS-TECHNOLOGY

With the AL-KO CHASSIS, we set standards in the van class. This applies for high frame chassis, but also for low frame chassis that enable low loading sills and low total vehicle heights. This has a positive effect on the fuel consumption and driving characteristics. A highlight is the 3-axle low-floor chassis with 13" tyres, consistent loading area as well as standard disc brakes and torsion guide rear axles.

FLEET OPTIMISATION

Why operate six vehicles when five perform the same transport capacity? We are the specialists for new innovative and intelligent solutions for optimising fleets. The basis is formed by our variable lightweight CHASSIS construction in a 2- or 3-axle variant with wide track chassis and independent suspension. This is the basis for additional load capacity, greater load volumes, more ergonomics – and much higher cost effectiveness.

Use the QR-Code or our internet adress for further information about Total Cost of Ownership:

www.alko-tech.com/en/save-fleet-costs



AL-KO CHASSIS TECHNOLOGY

LONG SERVICE LIFE

Hot dip-galvanized parts guarantee optimal protection against corrosion.

MORE PAYLOAD

Thanks to the intelligent light weight technology.

EASY TO SERVICE

Bolted frame parts are easy to service, ensuring shorter periods of downtime for repairs.

MORE TRANSPORT VOLUME

Customised solutions are available to suit a wide range of transport requirements, with variable wheelbases and overhangs, alongside a wide variety of axle and chassis gauges. These all combine to ensure optimal weight distribution throughout the range.



ESP¹⁾

ESP (Electronic Stability Program) is an optional safety feature now available for Fiat Ducato, Peugeot Boxer and Citroën Jumper³⁾ vehicles, with a 2 or 3 axle AL-KO Chassis. The ESP features include LAC (adaptive load control), ROM (rollover prevention), Traction + (electronic traction control), HH (hill start assistance) and HDC (hill descent assistance).

Figure shows special equipment!



TRAILING ARM AXLE

The ideally suited AL-KO trailing arm axle with independent suspension and torsion bar suspension ensures car-like ride comfort. Even greater levels of drive comfort can be achieved with the new AL-KO Comfort Suspension (ACS), the AL-KO Level Controller (ALC) and AL-KO Air Suspension. These optional systems offer increased suspension, and automatic leveling/lifting options.

WIDE TRACK CHASSIS

The chassis conversion can be up to 310 mm wider than the original chassis, resulting in significantly improved body control, excellent driving dynamics, maximum safety and better driving comfort.

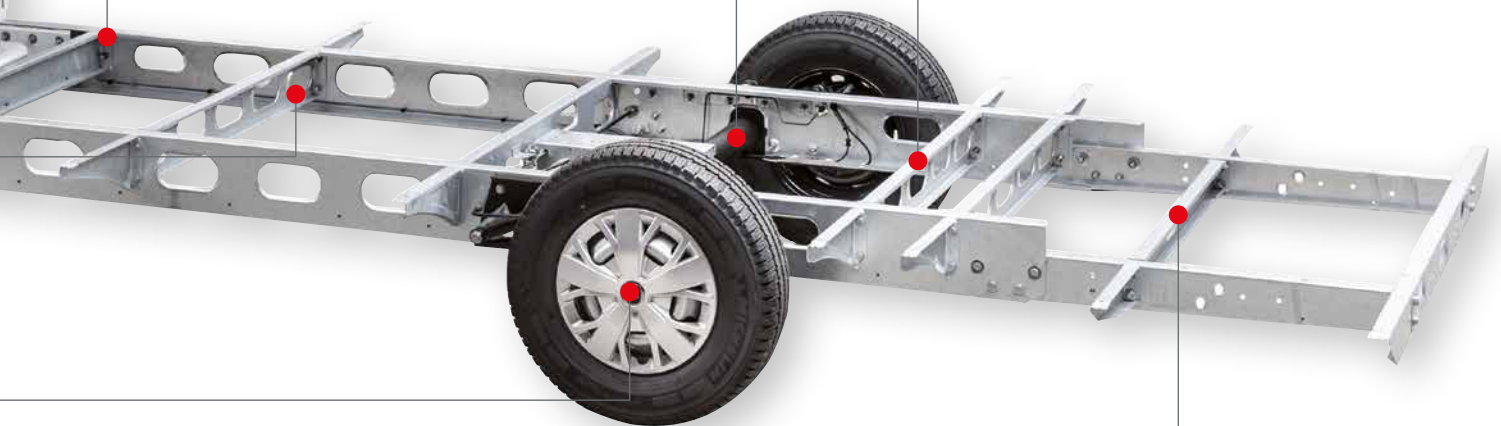

LOW-FRAME CHASSIS

The innovative low-frame chassis design enables a frame height reduction of up to 220 mm compared to the original chassis. This results in a lower loading height and a correspondingly reduced overall vehicle height. The lower centre of gravity can also significantly improve the road holding, cornering and crosswind sensitivity.

NOTE

Warranty work is to be carried out by the base vehicle manufacturers' dealer network.

¹⁾ ESP / ESC system functions relate to Fiat Ducato (Functions may differ for Peugeot / Citroën). For an overview regarding possible chassis types, chassis and wheelbase variants see page 10.

TECHNICAL DATA

AL-KO 2-AXLE LOW FRAME

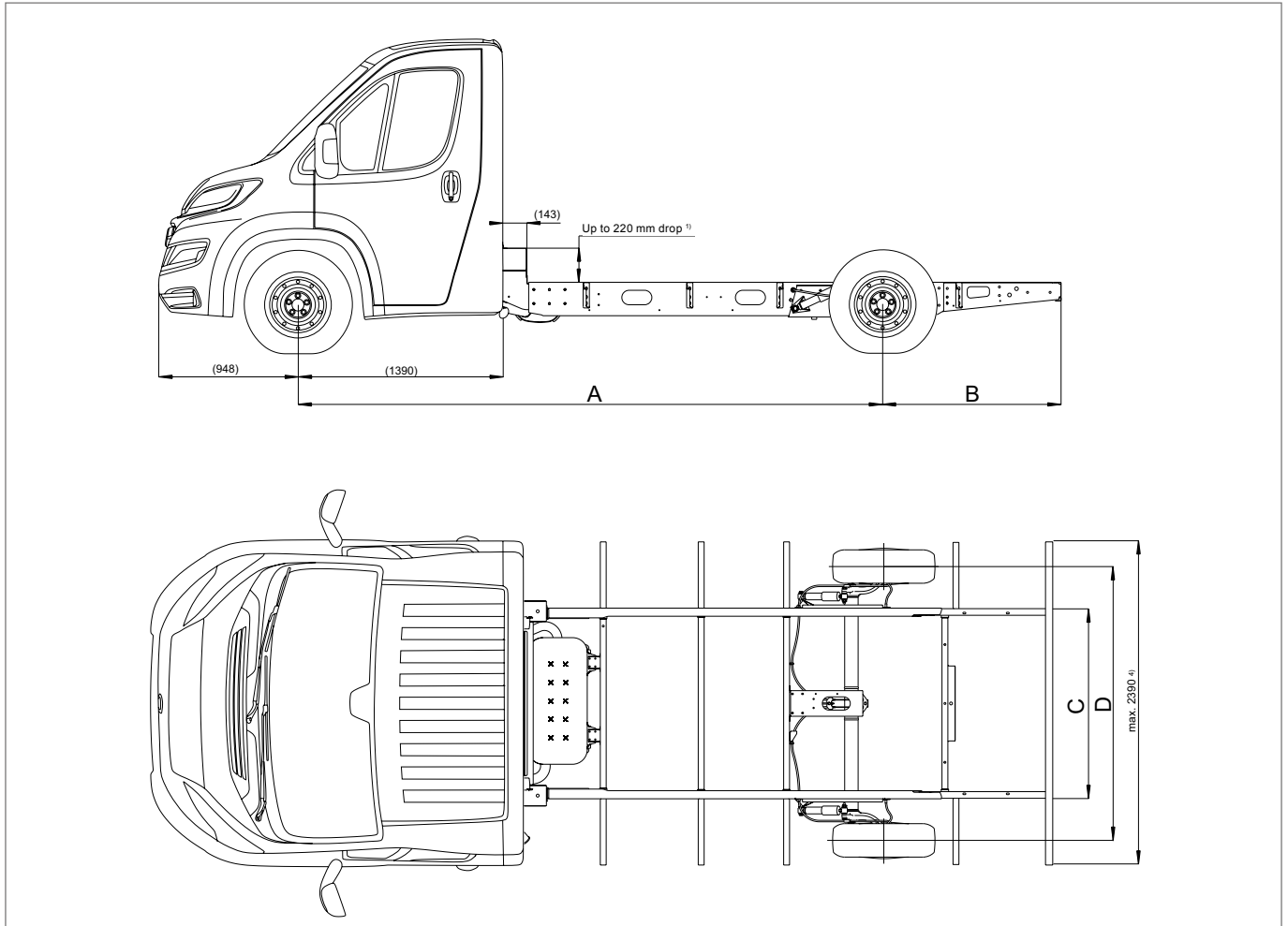

STANDARD DIMENSIONS⁶⁾

Wheelbase A (mm)	min. 3,000 ²⁾ ; 3,166 ²⁾ ; 3,320 ²⁾ ; 3,450; 3,643; 3,800; 3,896; 4,035; 4,143; 4,343; max. 4,700
Overhang B⁵⁾ (mm)	824; 924; 1,024; 1,147; 1,247; 1,344; 1,447; 1,547; 1,647; 1,747; 1,847; 1,947; max. 2,500
Frame width C (mm)	1,152; 1,295; 1,535
Gauge D (mm)	1,717; 1,860; 2,100 ³⁾

Spare wheel holder (optional) mounted starting from overhang (B) 1,147mm possible; Length sizes refer to gauge 1,860 mm.

Technical modifications reserved.

FRAME HEIGHT

(Approx values)

Tyre size	Frame height (mm)	
	empty	loaded
215/70 R 15C	520	420
225/70 R 15C		
225/75 R 16C	540	440

¹⁾ Other low frames available upon request

²⁾ Wheelbase 3,000mm, 3,166 mm and 3,320 mm only for type light

³⁾ For gauge 2,100 mm, the frame rails are cranked

Gauge 2,100 mm only startin from wheelbase 3,643mm

⁴⁾ Suitable outside mirrors should be used depending on the body width

⁵⁾ Overgang max. 60% of wheelbase A, max. 2,500 mm

⁶⁾ Deviating dimensions upon request

AL-KO 3-AXLE LOW FRAME

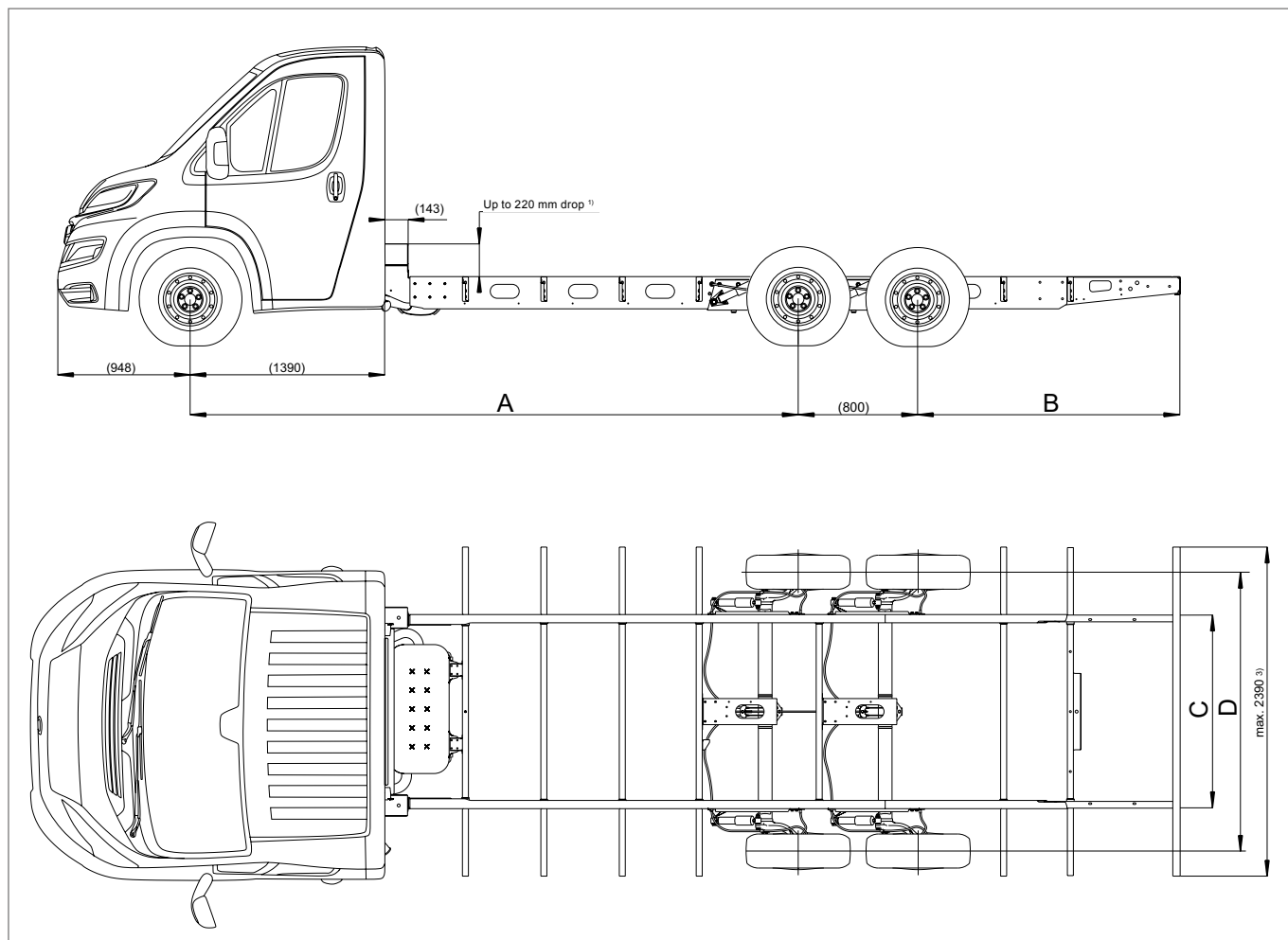

STANDARD DIMENSIONS⁵⁾

Wheelbase A (mm)	min. 3,450; 3,643; 3,800; 3,896; 4,035; 4,143; 4,343; 4,470; max. 4,700
Overhang B⁴⁾ (mm)	824; 924; 1,024; 1,147; 1,247; 1,344; 1,447; 1,547; 1,647; 1,747; 1,847; 1,947; max. 2,500
Chassis width C (mm)	1,152; 1,295; 1,535
Gauge D (mm)	1,717; 1,860; 2,100 ²⁾

NOTE: 3-axle low frame only approved for integral installations!

Other installations after consultation.

Spare wheel holder (optional) mounted starting from overhang (B) 1,147 mm possible;

Length sizes refer to gauge 1,860 mm.

Technical modifications reserved.

FRAME HEIGHT

(Approx. values)

Tyre size	Frame height (mm)	
	empty	loaded
225/75 R16 C	560	470

¹⁾ Other low frames available upon request

²⁾ For gauge 2,100 mm, the frame rails are cranked

Gauge 2,100 mm only starting from wheelbase 3,643 mm

³⁾ Suitable outside mirrors should be used depending on the body width

⁴⁾ Overhang max. 60% of wheelbase A, max. 2,500 mm

⁵⁾ Deviating dimensions upon request

OVERVIEW

FIAT / PEUGEOT / CITROËN (X290)

Permitted weights, axle loads, trailer loads and ESP availability

AL-KO Type	Base Vehicle Fiat Citroën Peugeot	Vehicle Class	Perm. total weight kg	Perm. Front axle load kg	Perm. Rear-axle load kg	Perm. towing capacity kg	Perm. Total train weight kg	ESP	Perm. AMC chassis variants options for ESP	Permissible wheelbase area options for ESP
AMC 35L	35L / 335	M1/N1	3,500	1,850	2,000	2,000	5,500	0	DF / ACS / ALC / APX2 / APX4	3,000 - 4,700 mm
AMC 37L	35L / 335	M1/N2	3,700	1,850	2,000	2,000	5,500	0	DF / ACS / ALC / APX2 / APX4	3,000 - 4,700 mm
AMC 38L	35L / 335	M1/N2	3,850	1,850	2,000	2,000	5,500	0	DF / ACS / ALC / APX2 / APX4	3,000 - 4,700 mm
AMC 35HA	40H / 440	M1/N1	3,500	2,100	2,500	2,000	5,500	0	DF / ACS / ALC / APX2 / APX4	3,450 - 4,700 mm
AMC 40H	40H / 440	M1/N2	4,000	2,100	2,500	2,000	6,000	0	DF / ACS / ALC / APX2 / APX4	3,450 - 4,700 mm
AMC 42H	40H / 440	M1/N2	4,250	2,100	2,500	2,000	6,000	0	DF / ACS / ALC / APX2 / APX4	3,450 - 4,700 mm
AMC 45H	40H / 440	M1/N2	4,500	2,100	2,500	2,000	6,000	0	DF / ACS / ALC / APX2 / APX4	3,450 - 4,700 mm
AMC 35HV	40H / 440	M1/N1	3,500	2,100	1,200/1,200	2,000	5,500	0	DF / ACS / APX2 / APX4	3,450 - 4,700 mm
AMC 45HS	40H / 440	M1/N2	4,500	2,100	1,600/1,600	2,000	6,000	0	DF / ACS / APX2 / APX4	3,450 - 4,700 mm
AMC 50HS	40H / 440	M1/N2	5,000	2,100	1,600/1,600	2,000	6,000	0	DF / ACS / APX2 / APX4	3,450 - 4,700 mm

INSTRUCTIONS

Speed Restriction

- In accordance with Directive 92/6 / EEC, as amended 2002/85 / EC, all vehicles of categories M2, M3, N2, N3 since 01/01/2005 must be fit with a speed limitation device
- This applies to all commercial vehicles with a permissible total mass exceeding 3,500 kg, including those on an AL-KO CHASSIS

Permissible Body Type

- 3-axle low frame only approved for the integrated bodies. Other constructions can be offered depending on consultation.

Please note the following for base vehicle specification:

Mandatory:

- Converters wiring (Electrical interface in B-Post) e.g. Fiat Part No. 081

Optional:

- Digital Tachometer (For class N2, MGW > 3500 kg) e.g. Fiat Part No. 650
(Standard equipment for Maxi 40)
- Mirror option for vehicle conversions with body width: 2.2m e.g. Fiat Part No. 036
(Not available via AL-KO - contact dealer for retrofitment)
- Mirror option for vehicle conversions with body width: 2.35m e.g. Fiat Part No. 042
(Not available via AL-KO - contact dealer for retrofitment)
- Rear light wiring for converter use (Not available via AL-KO) e.g. Fiat Part No. 391
- Rear light clusters for converter use (Not available via AL-KO) e.g. Fiat Part No. 4EA

If you should require any further information, please don't hesitate to contact us.

AL-KO CHASSIS

ACCESSORIES / SPECIAL EQUIPMENT

CLICK FIX STEADY LEGS



- | Robust construction for firm and secure footing
- | Fast and convenient operation: just a half-turn of the crank and the prop stand is in the vertical support position
- | Integrated free-swivelling mechanism
- | High-quality surface protection
- | Dynamic load capacity 500 kg, static 1,000 kg

ACS – AL-KO COMFORT SUSPENSION



- | Impressive suspension comfort
- | Superb driving stability and enhanced driving safety
- | Reduced noise levels inside the vehicle
- | Raising of the front axle standing height
- | Robust and durable
- | Maintenance-free
- | For 2 and 3 axles
- | Replaces the original front axle strut
- | Available as original equipment or for retrofitting

AIR PREMIUM FULL AIR SUSPENSION SYSTEM



- | Optimal suspension comfort
- | Fully automatic level control
- | Versatile lifting/lowering functions
- | Comes standard with soft touch remote control
- | Maintenance-free
- | Either for AL-KO rear axles (Air Premium X2)



SPARE WHEEL / SPARE WHEEL HOLDER



- | Secure spare wheel attachment to the chassis rear
- | Problem-free retrofitting for most AL-KO CHASSIS with a straight rear structure.
- | Low assembly effort – easy assembly with standard on-board tool kits

TOWING HITCH



- | Customized exactly to the AL-KO CHASSIS
- | Offer the highest degree of safety
- | Only for AL-KO CHASSIS and/or AL-KO frame extensions
- | Low assembly effort
- | High-quality surface protection

LIGHT BRACKET



- | Available in black (other colours upon request)
- | Optional with position lights incl. holder (short/long)
- | Optional with LED lighting



APPLICATION EXAMPLES



Promotional vehicle



Horse transporter



Refrigerated box vehicle



Event vehicle



Sales vehicle



Sales vehicle

ALOIS KOBER GMBH
Ichenhauser Straße 14
89359 Kötz
Germany
Phone +49 8221 97-0
info@alko-tech.com
www.alko-tech.com

AL-KO Kober Limited
South Warwickshire Business Park
Kineton Road, Southam, Warwickshire, CV47 0AL
United Kingdom
Phone +44 1926 818 500
mail.uk@alko-tech.com
www.alko-tech.com/uk